

3/8" – 4"

Advantages/Benefits

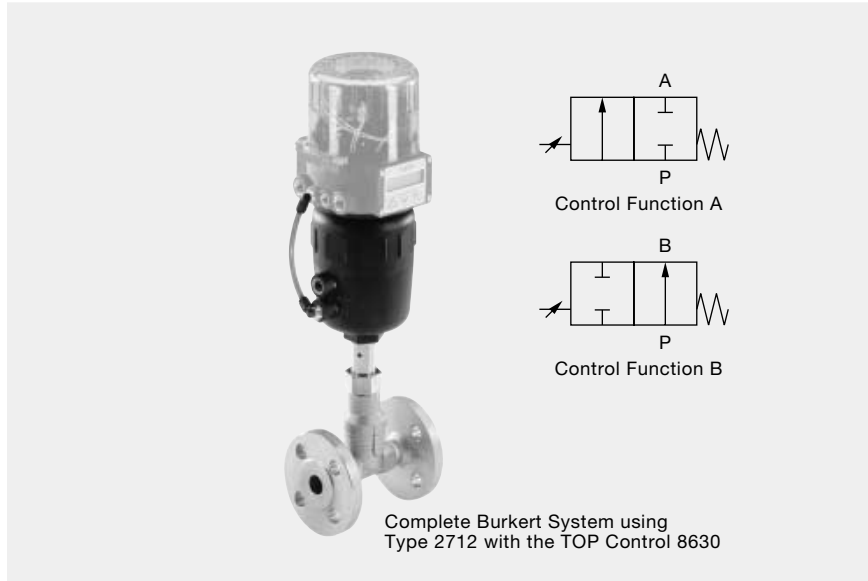

- ▶ Fully integrated in Burkert's Easy Process Control Systems
- ▶ Interchangeable trims (single and double reduction)
- ▶ Integrated, cascade process controller with PID algorithm
- ▶ Various surface finishes
- ▶ Superfine control
- ▶ Autotune "Automatic" self-adjustment of basic parameters means autotune for the valve and for PID parameters

Complete Burkert System using Type 2712 with the TOP Control 8630

Control Valve Type 2712 consists of a globe valve body with pneumatic piston actuator and parabolic plug/seat system. This results in a favorable valve characteristic for continuous variation of the flow as a function of the parabolic plug position. The Type 2712 can be actuated by the TOP Control Type 8630 or SIDE Control Type 1067 and 8635. TOP Control/SIDE Control forms a mechanical and functional unit with the integrated pneumatic positioner as a complete control valve system. With this control valve system, every need in the proportional control of fluids can be solved.

Applications

Process Specification

Materials

- | | |
|---------------------------------------|---|
| Body | Cast Stainless Steel 316 L (conforms to 1.4409) |
| Actuator | PA (Polyamide) |
| Sealing IEC 534-4/EN 1349 | <ul style="list-style-type: none"> • SS/SS Class IV • PTFE/SS Class VI |
| Process media (for gases and liquids) | <ul style="list-style-type: none"> • For neutral gases, water, alcohols, oils, fuels, hydraulic liquids, salt solutions, lyes, organic solvents, steam (150 PSI/356°F) |
| Viscosity | Max. 600 mm ² /s |
| Packing gland | Live loaded PTFE V-rings (silicone grease) |
| Operating pressure | 360 PSI (PN 25) |
| Temperatures | |
| Fluid | 14°F to 356°F |
| Ambient | 14°F to 140°F |
| Control media | |
| Pilot pressure | Instrument air class 3 |
| Pilot connection | DIN ISO 8573-1 |
| Flow direction | 80 - 100 PSI |
| Interchangeable seat | NPT 1/4 stainless steel (SS) |
| Control ratio | Below seat |
| | Three Different Cvs-values per port size |
| | Valve characteristics (See flow-rate characteristics on page 2) |
| | Cvs/Cvo 50:1 |



Pharmaceutical

- Sterilizers; Steam

Food & Beverage

- CIP / SIP; Steam
- Auxiliary Processes

Water Treatment

- Air Control
- Chemical Dosing

Cosmetics

- CIP / SIP; Steam

Textile

- Steam; Water; Air; Dyeing

Flange Port connection specifications:

- | | |
|------|---|
| ANSI | <ul style="list-style-type: none"> • ANSI B16.5 RF¹⁾ Class 150 • Face-to-Face ISA S75.03 (ANSI B16.10) |
| DIN | <ul style="list-style-type: none"> • DIN 2634 RF¹⁾ • Face-to-Face EN 558-1 (DIN 3202) |
| JIS | <ul style="list-style-type: none"> • JIS B2238 ordinary type JIS 10K RF¹⁾; • Face-to-Face JIS B2002 series 20 ANSI B16.10 (EN 558-2) |

Size [inch]	Orifice (seat)			Actuator size [mm]	C _v			Weight with controller Type 8630 [lbs]
	1 [inch]	2	3		1	2	3	
3/8	-	1/4	3/8	F-80	-	2.35	3.18	9.90
1/2	1/4	3/8	1/2	F-80	2.47	3.65	5.06	9.90
3/4	3/8	1/2	3/4	F-80	3.76	6.12	8.35	11.44
1	1/2	3/4	1	F-80	6.23	8.47	14.11	13.64
1-1/4	3/4	1-1/4		G-100	9.41	15.29	20.93	22.44
1-1/2	1	1-1/4	1-1/2	G-100	15.99	23.76	27.99	24.42
2	1-1/4	1-1/2	2	H-125	24.70	28.93	43.51	36.52

¹⁾ Raised face (RF)



Flow curve and description

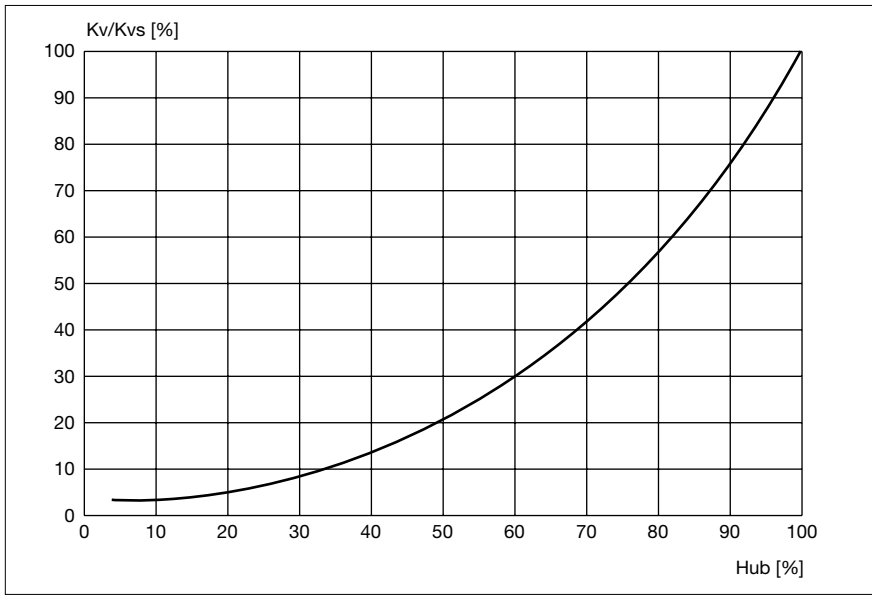

Remarks on the flow characteristic

- Equipercentile parabolic plug
(Linear plug can also be supplied)
- Flow characteristic runs within
DIN/IEC 534-2-4
- Theoretical control ratio
 $C_{vs}/C_{vo} = 50 : 1$
other control ratios can also be realized
- C_{vR} value at 5% of stroke for
DN > 10 mm
 C_{vR} value at 10% of stroke for
DN ≤ 10 mm
(C_{vR} value = smallest C_v value at which
the gradient tolerance to DIN/IEC
534-2-4 is still complied with)

Cv Values

Size [inch]	Orifice (seat)		Stroke [%]										
	[mm]	[inch]	5	10	20	30	40	50	60	70	80	90	100
3/8	8	1/4	0.07	0.08	0.11	0.14	0.21	0.31	0.49	0.72	1.08	1.76	2.35
3/8	10	3/8	0.11	0.13	0.15	0.22	0.35	0.56	0.86	1.18	1.88	2.70	3.18
1/2	8	1/4	0.08	0.09	0.13	0.15	0.22	0.32	0.51	0.74	1.12	1.88	2.47
1/2	10	3/8	0.11	0.13	0.26	0.22	0.36	0.58	0.88	1.29	2.00	2.94	3.65
1/2	15	1/2	0.16	0.20	0.18	0.41	0.61	0.94	1.41	2.12	3.18	4.35	5.06
3/4	10	3/8	0.13	0.14	0.19	0.24	0.39	0.61	0.91	1.41	2.12	3.06	3.76
3/4	15	1/2	0.16	0.20	0.26	0.41	0.61	0.94	1.41	2.12	3.41	4.70	6.12
3/4	20	3/4	0.24	0.29	0.35	0.53	0.82	1.29	1.88	2.82	4.12	6.12	8.35
1	15	1/2	0.16	0.20	0.26	0.41	0.61	0.94	1.41	2.12	3.41	4.82	6.23
1	20	3/4	0.24	0.29	0.36	0.55	0.82	1.29	1.88	2.94	4.47	6.35	8.47
1	25	1	0.41	0.45	0.76	1.18	1.76	2.59	4.00	6.00	8.23	11.05	14.11
1-1/4	20	3/4	0.26	0.29	0.41	0.59	0.88	1.29	1.88	2.94	4.47	6.82	9.41
1-1/4	25	1	0.47	0.55	0.86	1.29	1.88	2.94	4.35	6.35	8.82	12.11	15.29
1-1/4	32	1-1/4	0.56	0.71	1.00	1.53	2.47	3.65	5.29	8.00	12.00	16.46	20.93
1-1/2	25	1	0.47	0.59	0.88	1.29	2.00	3.06	4.47	6.59	9.41	12.58	15.99
1-1/2	32	1-1/4	0.56	0.71	1.00	1.53	2.47	3.76	5.41	8.11	12.94	17.64	23.76
1-1/2	40	1-1/2	0.71	0.82	1.29	2.00	3.18	4.70	7.06	10.82	16.23	21.40	27.99
2	32	1-1/4	0.56	0.71	1.06	1.53	2.47	3.76	5.41	8.11	13.64	18.82	24.70
2	40	1-1/2	0.71	0.82	1.18	2.00	3.06	4.70	6.94	10.82	16.46	22.23	28.93
2	50	2	1.05	1.29	2.23	3.41	5.29	8.0	12.35	18.23	25.87	34.45	43.51

DTS 1000079076 EN Version: A Status: RL (released | freigegeben | validé) printed: 17.07.2008

2/2-Way Globe Control Valve, Pneumatically Operated

Cast Stainless Steel Body with Flanges

Type 2712

Intelligent Globe Control Valve

Ordering chart: Globe Valve Systems

Flange • ANSI B16.5 Class 150 • Face-to-Face ISA S75.03 (ANSI 16.10)					Flow below seat		
Circuit Function	Size [inch]	Orifice [mm] [inch]	Actuator size ø [mm]	Op. pressure ≤ 365° F [PSI]	Item-No. seal system* SS/SS	Item-No. seal system* PTFE/SS	
A Normally Closed	1/2	8 1/4	F-80	232	146 680 A	146 966 U	
	1/2	10 3/8	F-80	232	146 702 C	146 990 Z	
	1/2	15 1/2	F-80	232	146 730 B	147 018 S	
	3/4	10 3/8	F-80	232	146 716 Z	147 004 V	
	3/4	15 1/2	F-80	232	146 744 D	147 032 Q	
	3/4	20 3/4	F-80	232	146 772 H	147 060 G	
	1	15 1/2	F-80	232	146 758 K	147 046 W	
	1	20 3/4	F-80	232	146 786 Y	147 074 S	
	1	25 1	F-80	232	146 812 J	147 100 E	
	1-1/4	20 3/4	G-100	232	146 800 B	147 088 Z	
	1/4	25 1	G-100	232	146 824 N	147 114 P	
	1-1/4	32 1-1/4	G-100	232	146 850 C	147 140 D	
	1-1/2	25 1	G-100	232	146 836 J	147 126 K	
	1-1/2	32 1-1/4	G-100	232	146 862 U	147 152 V	
	1-1/2	40 1-1/2	G-100	232	146 890 V	147 179 G	
	2	32 1-1/4	H-125	232	146 876 S	147 165 S	
	2	40 1-1/2	H-125	232	146 904 X	147 196 J	
	2	50 2	H-125	232	146 918 U	147 210 B	
	3	on request					
	4	on request					
	B Normally Open	1/2	8 1/4	F-80	232	146 684 S	146 972 S
		1/2	10 3/8	F-80	232	146 709 K	146 997 L
		1/2	15 1/2	F-80	232	146 737 W	147 025 R
		3/4	10 3/8	F-80	232	146 723 Y	147 011 K
3/4		15 1/2	F-80	232	146 751 C	147 039 X	
3/4		20 3/4	F-80	232	146 779 Q	147 067 T	
1		15 1/2	F-80	232	146 765 A	147 053 V	
1		20 3/4	F-80	232	146 793 X	147 081 J	
1		25 1	F-80	232	146 817 P	147 107 Z	
1-1/4		20 3/4	G-100	232	146 806 V	147 094 P	
1-1/4		25 1	G-100	232	146 830 Y	147 120 Z	
1-1/4		32 1-1/4	G-100	232	146 856 W	147 146 X	
1-1/2		25 1	G-100	232	146 843 Z	147 133 J	
1-1/2		32 1-1/4	G-100	232	146 869 B	147 158 B	
1-1/2		40 1-1/2	G-100	232	146 897 Q	147 189 T	
2		32 1-1/4	H-125	232	146 883 J	147 172 Z	
2		40 1-1/2	H-125	232	146 911 M	147 203 H	
2		50 2	H-125	232	146 923 R	147 217 W	
3		on request					
4		on request					



*seal system: SS/SS plug stainless steel / seat stainless steel
PTFE/SS plug PTFE / seat stainless steel

Flange • DIN 2634 • Face-to-Face EN 558-1 (DIN 3202)					Flow below seat		
Circuit Function	Port size [inch]	Orifice [inch]	Actuator size ø [mm]	Op. pressure ≤ 365° F [PSI]	Item-No. seal system* SS/SS	Item-No. seal system* PTFE/SS	
A Normally Closed	3/8	1/4	F-80	232	146 669 J	146 955 Z	
	3/8	3/8	F-80	232	146 691 Z	146 979 H	
	1/2	1/4	F-80	232	146 681 X	146 967 V	
	1/2	3/8	F-80	232	146 703 D	146 991 N	
	1/2	1/2	F-80	232	146 731 Y	147 019 T	
	3/4	10	F-80	232	146 717 S	147 005 W	
	3/4	1/2	F-80	232	146 745 E	147 033 R	
	3/4	3/4	F-80	232	146 773 A	147 061 V	
	1	1/2	F-80	232	146 759 L	147 047 X	
	1	3/4	F-80	232	146 787 Z	147 075 T	
	1	1	F-80	232	146 813 K	147 101 T	
	1-1/4	3/4	G-100	232	146 801 Y	147 089 S	
	1-1/4	1	G-100	232	146 825 P	147 115 Q	
	1-1/4	1-1/4	G-100	232	146 851 Z	147 141 S	
	1-1/2	1	G-100	232	146 837 K	147 127 L	
	1-1/2	1-1/4	G-100	232	146 863 V	147 153 W	
	1-1/2	1-1/2	G-100	232	146 891 J	147 180 W	
	2	1-1/4	H-125	232	146 877 T	147 166 T	
	2	1-1/2	H-125	232	146 905 Y	147 197 K	
	2	2	H-125	232	146 200 R	147 211 Y	
	B Normally Open	3/8	1/4	F-80	232	146 675 G	146 961 X
		3/8	3/8	F-80	232	146 697 X	146 985 Q
		1/2	1/4	F-80	232	146 685 T	146 973 T
		1/2	3/8	F-80	232	146 710 F	146 998 V
1/2		1/2	F-80	232	146 738 F	147 026 J	
3/4		3/8	F-80	232	146 724 Z	147 012 L	
3/4		1/2	F-80	232	146 752 D	147 040 C	
3/4		3/4	F-80	232	146 780 E	147 068 C	
1		1/2	F-80	232	146 766 B	147 054 W	
1		3/4	F-80	232	146 794 Y	147 082 K	
1		1	F-80	232	146 818 Y	147 108 A	
1-1/4		3/4	G-100	232	146 807 W	147 095 Q	
1-1/4		1	G-100	232	146 831 M	147 121 N	
1-1/4		1-1/4	G-100	232	146 857 X	147 147 Y	
1-1/2		1	G-100	232	146 844 S	147 134 K	
1-1/2		1-1/4	G-100	232	146 870 G	147 159 C	
1-1/2		1-1/2	G-100	232	146 898 Z	147 190 Y	
2		1-1/4	H-125	232	146 884 K	147 173 S	
2		1-1/2	H-125	232	146 912 N	147 204 A	
2		2	H-125	232	146 924 J	147 218 F	



DTS 1000079076 EN Version: A Status: RL (released | freigegeben | validé) printed: 17.07.2008

2/2-Way Globe Control Valve, Pneumatically Operated

Cast Stainless Steel Body with Flanges

Type 2712

Intelligent Globe Control Valve

Flange					Flow below seat		
<ul style="list-style-type: none"> JIS B2238 ordinary type; JIS 10K Face-to-Face JIS B2002 series 20 (ANSI B16.10) (EN 558-2) 							
Circuit Function	Port size (tube) [mm]	Orifice (seat) [mm]	Actuator size ϕ [mm]	Op. pressure $\leq 356^\circ\text{F}$ [PSI]	Item-No. seal system* SS/SS	Item-No. seal system* PTFE/SS	
A	15	8	F-80	232	148 415 W	148 496 Y	
	15	10	F-80	232	148 421 U	148 502 E	
	15	15	F-80	232	148 430 H	148 510 H	
	20	10	F-80	232	148 426 Z	148 506 A	
	20	15	F-80	232	148 434 Z	148 514 Z	
	20	20	F-80	232	148 443 A	148 522 Z	
	25	15	F-80	232	148 438 D	148 518 D	
	25	20	F-80	232	148 447 E	148 526 V	
	25	25	F-80	232	148 455 E	148 534 V	
	32	20	G-100	232	151 473 T	148 530 D	
	32	25	G-100	232	148 459 J	148 538 H	
	32	32	G-100	232	148 468 K	148 546 H	
	40	25	G-100	232	148 463 E	148 542 D	
	40	32	G-100	232	148 472 F	148 550 R	
	40	40	G-100	232	148 481 Z	148 558 M	
	50	32	H-125	232	148 477 C	148 554 H	
	50	40	H-125	232	148 485 V	148 562 H	
	50	50	H-125	232	148 489 H	148 566 D	
	B	15	8	F-80	232	148 417 Y	148 498 A
		15	10	F-80	232	148 423 W	148 504 G
15		15	F-80	232	148 432 X	148 512 X	
20		10	F-80	232	148 428 B	148 508 L	
20		15	F-80	232	148 436 T	148 516 T	
20		20	F-80	232	148 445 C	148 524 T	
25		15	F-80	232	148 441 G	148 520 B	
25		20	F-80	232	148 449 Q	148 528 F	
25		25	F-80	232	148 457 G	148 536 X	
32		20	G-100	232	148 452 B	148 532 T	
32		25	G-100	232	148 461 C	148 540 P	
32		32	G-100	232	148 470 R	148 548 K	
40		25	G-100	232	148 465 G	148 544 F	
40		32	G-100	232	148 474 H	148 552 F	
40		40	G-100	232	148 483 T	148 560 K	
50		32	H-125	232	148 479 N	148 556 B	
50		40	H-125	232	148 487 X	148 564 B	
50		50	H-125	232	148 492 U	148 568 P	



Dimensions [mm]

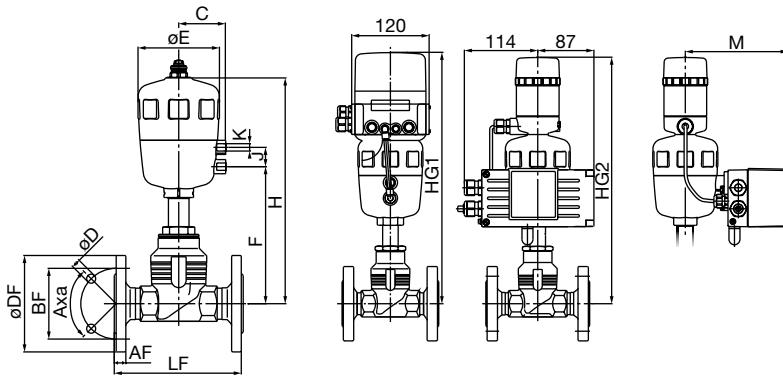

Port size	8630		1067		8635	
	HG ¹	HG ²	M	HG ²	M	
3/8	391	384	145	384	159	
1/2	391	384	145	384	159	
3/4	389	379	145	379	159	
1	389	382	145	382	159	
1-1/4	476	469	158	469	172	
1-1/2	481	474	158	474	172	
2	618	511	171	511	185	

Port size	Act. size ϕ	All Actuators							DIN Flange					ANSI Flange					JIS Flange							
		C	E	F	H	K	J	HG	Axa	DF	LF	BF	AF	D	DF	LF	BF	AF	D	DF	LF	BF	AF	D		
3/8	F-80	60	101	166	264	G 1/4	24	see sep. chart	4x90°	90	130	60	16	14	-	-	-	-	-	-	-	-	-	-	-	-
1/2	F-80	60	101	166	264	G 1/4	24			95	130	65	16	14	89.0	184	60.5	11.2	15.7	95	108	70	12	15		
3/4	F-80	60	101	180	259	G 1/4	24			105	150	75	18	14	99.0	184	69.9	12.7	15.7	100	117	75	14	15		
1	F-80	60	101	164	262	G 1/4	24			115	160	85	18	14	108.0	184	69.9	12.7	15.7	100	127	75	14	15		
1-1/4	G-100	73	127	208	346	G 1/4	30			140	180	100	18	18	-	-	-	-	-	135	140	100	16	19		
1-1/2	G-100	73	127	213	351	G 1/4	30			150	200	110	18	18	127.0	222	98.6	17.5	15.7	140	165	105	16	19		
2	H-125	86	153	225	388	G 1/4	30			165	230	125	20	18	152.4	254	120.7	19.1	19.1	155	203	120	16	19		

Additional Process Connections Available:

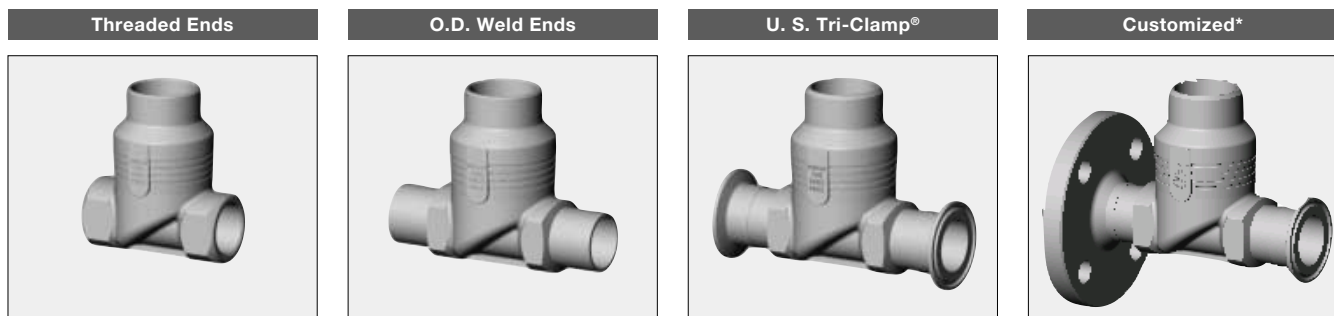

*e.g. one side with flange, other side Tri-Clamp®

DTS 1000079076 EN Version: A Status: RL (released | freigegeben | validé) printed: 17.07.2008

Valve Actuation System: TOP Control

Type: 8630

TOP Control Continuous Type 8630 forms a mechanical and functional unit with the pneumatic actuator. Main functional groups of the TOP Control continuous are:

- Positioner and process controller in one device, integrated PID
- Position measuring system for continuous feedback of the actual position of the pneumatic actuator and the valve
- Microprocessor controlled electronics for signal processing, setpoint/ process value comparison
- Pneumatic positioning system for single and double-acting actuators whose integrated pilot valves are driven by pulse-width modulation

TOP Control continuous can be used in a variety of different applications in fluid control solutions for proportional control of fluids.



Valve Actuation System: SIDE Control 3-wire

Type: 1067

SIDE Control Type 1067 is a 3-wire process controller and positioner. Functions include position measuring system, electropneumatic actuator system and microprocessor electronics. Main functional groups of the SIDE Control unit are:

- Positioner and process controller in one device, integrated PID
- Position measuring system for continuous feedback of the actual position of the pneumatic actuator and the valve
- Microprocessor controlled electronics for signal processing, setpoint/ process value comparison
- Pneumatic positioning system for single and double-acting actuators whose integrated pilot valves are driven by pulse-width modulation



Valve Actuation System: SIDE Control 2-wire

Type: 8635

SIDE Control Type 8635 is a 2-wire electropneumatic process controller and positioner for pneumatically operated process valves. The input signal of 4 - 20 mA serves to transmit the control signal and to supply the device with power at the same time.

- HART protocol is modulated onto the current signal (optional)
- Signal processing, control and drive of the internal positioning system are carried out by microprocessor controlled electronics
- The software function X-tune enables automatic adaptation of the positioner to the control valve
- Parametrization and operation are performed via three keys and a display with plain text, or via the HART protocol (optional)
- To build up a decentralized control system, SIDE Control is equipped with a process controller with integrated PID. In this case, a process control loop is superimposed on the positioning loop in a cascade structure
- This compact, robust design is suitable for use in chemical and process engineering in FM Class1 Div1 and Intrinsically Safe (IS) locations



2/2-Way Globe Control Valve, Pneumatically Operated Cast Stainless Steel Body with Flanges

Type 2712 Intelligent Globe Control Valve

Globe Valve Systems

A globe control valve system consists of a proportional globe valve Type 2712 and a valve actuation system TOP Control Type 8630 or SIDE Control Type 1067 or 8635.

Burkert offers a wide range of valve actuation systems suitable for the proportional globe valve.

Example for variations of continuous globe valve systems



DTS 1000079076 EN Version: A Status: RL (released | freigegeben | validé) printed: 17.07.2008

Burkert Contromatic USA
2602 McGaw Avenue
Irvine, CA 92614
Tel. 949.223.3100
Fax 949.223.3198
www.burkert-usa.com

Burkert Contromatic Inc.
760 Pacific Road, Unit 3
Oakville, Ontario, Canada L6L 6M5
Tel. 905.847.5566
Fax 905.847.9006
www.burkert.ca

In case of special requirements
please consult for advice.

We reserve the right to make technical
changes without notice.

US_2712FL_07/01