

## 2/2-way proportional valve

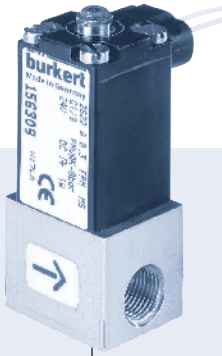

Type 2822 can be combined with...

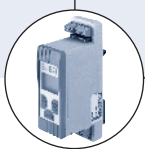

**Type 8605**

Digital control electronics  
DIN-rail version

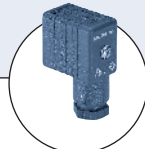

**Type 2507**

Cable plug

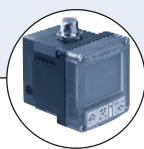

**Typ 8611**

Universal Controller

- Excellent dynamics and turn-down ratio
- 0 to 232 PSI<sup>1)</sup>
- DN 0.05 to 1.0 mm
- 1/8" or sub-base version

The direct-acting proportional valve Type 2822 can be used as a control valve for process control and is suitable for technical vacuum. A special design minimizes frictional and stick-slip effects and provides an excellent span, repeatability and sensitivity.

The valve is driven either by DC or by a high-frequency PWM signal. With the input signal at zero, it closes tightly owing to an elastomer seat seal. Because of its almost silent operation, the valve is especially suitable for medical applications.

### Valve operation A

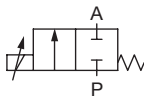

direct acting 2-way  
proportional valve  
normally closed

Valve control takes place through the control electronics of Type 8605, which converts an analogue input signal into a PWM signal<sup>2)</sup>.

Further, functional features of the Type 8605 electronic control unit:

- Temperature compensation for coil heating by internal current regulation
- Simple zero and span settings
- Ramp function to dampen fast status changes

<sup>1)</sup> Pressure data [PSI]: Overpressure with respect to atmospheric pressure

<sup>2)</sup> PWM pulse-width modulation

<sup>3)</sup> Characteristic data of control behaviour depends on process conditions

### Technical data - valve

<b>Body material</b>	Brass, Stainless steel
<b>Seal material</b>	FKM, others on request
<b>Media</b>	Neutral gases, liquids
<b>Medium temperature</b>	14°F to 194°F (-10°C to +90°C)
<b>Ambient temperature</b>	max. 131°F (+55°C)
<b>Viscosity</b>	max. 21 cSt
<b>Operating voltage</b>	24 V DC
<b>Power consumption</b>	1 W (to DN 0.4) 2 W (DN 0.6 to DN 1.0)
<b>Duty cycle</b>	100 % continuously rated
<b>Port connection</b>	NPT 1/8, Sub-base, G 1/8, others on request
<b>Electric connection</b>	Flying leads, 30 cm or cable plug Type 2507 Form B, Industrial standard on request
<b>Installation</b>	As required, preferably with actuator in upright position
<b>Response time (10-90%)</b>	< 10ms
<b>Typical control data<sup>3)</sup></b>	
Hysteresis	< 10 %
Repeatability	< 0.25 % F.S.
Sensitivity	< 0.1 % F.S.
Width of backlash	< 0.1 % F.S.
Turn-down ratio	1:500
<b>Protection class - valve</b>	IP65

### Technical data - control electronics Type 8605 (see separate datasheet)

### Characteristics of a proportional valve

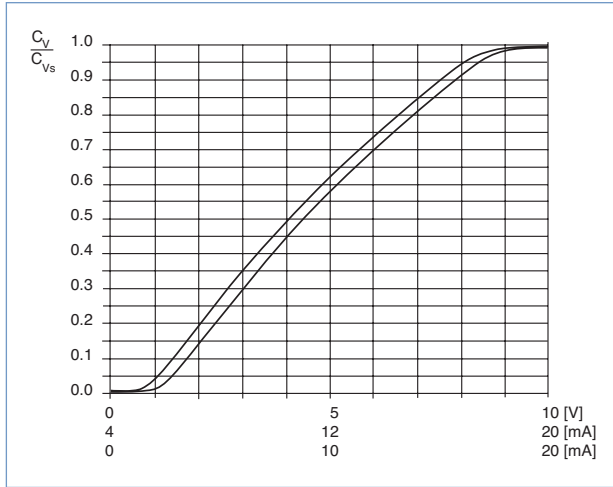

### Advice for valve sizing

In continuous flow applications, the choice of appropriate valve size is much more important than with on/off valves. The optimum size should be selected such that the resulting flow in the system is not unnecessarily reduced by the valve. However, a sufficient part of the pressure drop should be taken across the valve even when it is fully opened.

**Recommended value:  $\Delta p_{\text{valve}} > 30\%$  of total pressure drop within the system**

**For that reason take advantage of Bürkert competent engineering services during the planning phase!**

### Determination of the $C_v$ value

Pressure drops	$C_v$ value for liquids [GPM]	$C_v$ value for air and gasses [SCFM]
Subcritical ( $p_2 > p_1 \times .53$ )	$C_v = \frac{Q_L \sqrt{Sg}}{\sqrt{\Delta p}}$	$C_v = \frac{Q_g \sqrt{Sg}}{\sqrt{\Delta p \times p_2}}$
Supercritical ( $p_2 < p_1 \times .53$ )	$C_v = \frac{Q_L \sqrt{Sg}}{\sqrt{\Delta p}}$	$C_v = \frac{Q_g \times 2 \sqrt{Sg}}{p_1}$

- $C_v$  = Liquids – flow coefficient in GPM at 1 PSI  $\Delta p$   
Gasses – flow coefficient in SCFM for each PSIG of inlet pressure
- $Sg$  = Specific gravity (Specific gravity of air and water @ 60°F=1)
- $p_1$  = Inlet pressure in PSIA
- $p_2$  = Outlet pressure in PSIA
- $\Delta p$  = Differential pressure ( $p_1 - p_2$ )
- PSIA = Gauge pressure (PSIG) + 14.7
- $Q_L$  = Liquid flow in GPM
- $Q_g$  = Gas flow in SCFM

## Ordering chart

All devices with FKM seal and flying electrical leads with 30 cm cable.

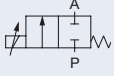
Circuit function	Orifice [mm]	Port connection	C <sub>v</sub> value water [GPM] <sup>1)</sup>	QNn value [l/min] <sup>2)</sup>	Maximum pressure [PSI] <sup>3)</sup>	Power consumption [W]	Maximum coil current [mA]	Item no. Brass body	Item no. Stainless steel body
	0.05	sub-base FK01	0.00007	0.06	145	1	65	184 760	184 761
		G 1/8	0.00007	0.06	145	1	65	on request	on request
		NPT 1/8	0.00007	0.06	145	1	65	on request	on request
	0.1	sub-base FK01	0.00029	0.27	145	1	65	184 749	184 759
		G 1/8	0.00029	0.27	145	1	65	on request	on request
		NPT 1/8	0.00029	0.27	145	1	65	on request	on request
	0.2	sub-base FK01	0.0011	1	145	1	65	159 260	184 748
		G 1/8	0.0011	1	145	1	65	on request	on request
		NPT 1/8	0.0011	1	145	1	65	on request	on request
	0.3	sub-base FK01	0.0023	2	145	1	65	156 308	156 310
		G 1/8	0.0023	2	145	1	65	156 309	156 311
		NPT 1/8	0.0023	2	145	1	65	164 581	164 622
	0.4	sub-base FK01	0.0046	4	116	1	65	156 295	152 693
		G 1/8	0.0046	4	116	1	65	156 296	156 297
		NPT 1/8	0.0046	4	116	1	65	164 582	164 623
	0.6	sub-base FK01	0.011	11	87	2	90	156 298	160 571
		G 1/8	0.011	11	87	2	90	159 691	160 595
		NPT 1/8	0.011	11	87	2	90	164 606	164 624
	0.8	sub-base FK01	0.021	19	43.5	2	90	156 301	160 596
		G 1/8	0.021	19	43.5	2	90	156 302	156 303
		NPT 1/8	0.021	19	43.5	2	90	164 583	164 625
	1.0	sub-base FK01	0.031	29	29	2	90	156 304	156 306
		G 1/8	0.031	29	29	2	90	156 305	156 307
		NPT 1/8	0.031	29	29	2	90	164 584	164 626

<sup>1)</sup> C<sub>v</sub> value: Flow rate value for water, measured at 68°F (+20°C) and 1 PSI pressure differential over a fully opened valve.

<sup>2)</sup> QNn value: Flow rate value for air with inlet pressure of 87 PSI<sup>1)</sup>, 14.5 PSI pressure differential and 68°F (+20°C).

<sup>3)</sup> Pressure data [PSI]: Overpressure with respect to atmospheric pressure

▪ **Please note** that the valves are delivered without control electronics (please see the datasheet for Type 8605)

### Further versions on request



#### Materials

Seal material FFKM - Resistant to aggressive media  
Seal material EPDM



#### Analytical

Oxygen version  
Part oil-, fat- and silicon free



#### Electrical Connection

12 V Coil  
Cable plug Type 2507 Form B, Industrial standard

Dimensions [mm]

Flying leads connection

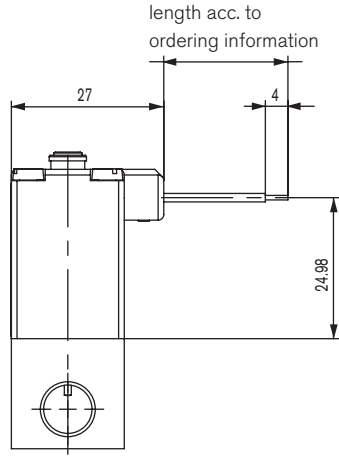

Threaded body  
(NPT 1/8, G 1/8)

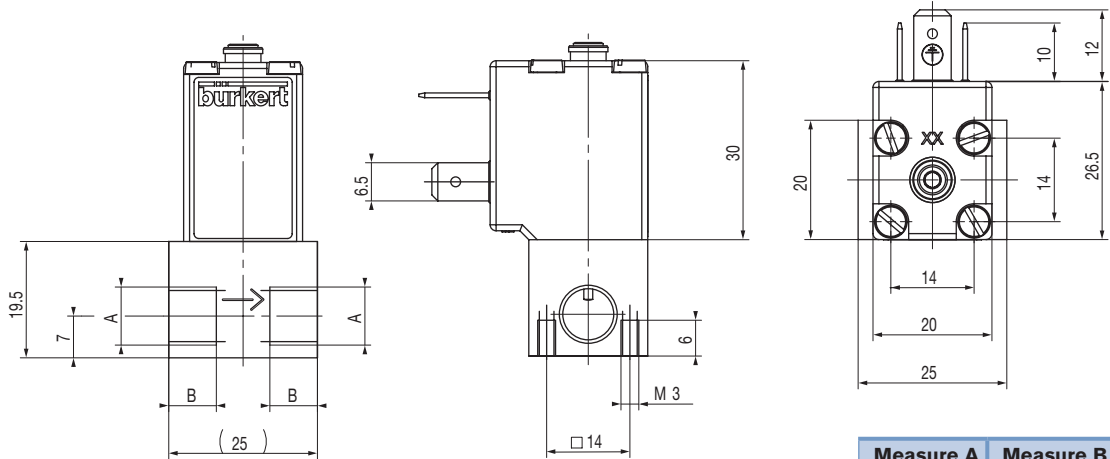

Measure A	Measure B
NPT 1/8	7
G 1/8	8

Sub-base body

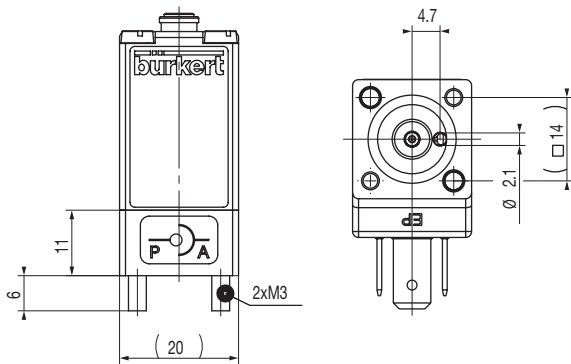

For product inquiries, use the specification sheet for proportional valves!

**Note**  
You can fill out the fields directly in the PDF file before printing out the form.

**Design data for proportional valves**

▶ Please fill out this form and send to your local Bürkert Sales Centre\* with your inquiry or order

Company	Contact person
Customer no.	Dept.
Address	Tel./Fax
Town / Postcode	E-Mail

<input type="checkbox"/> = Mandatory fields	<input type="text"/> Quantity	<input type="text"/> Desired delivery date
<b>Process data</b>		
<input type="checkbox"/> Medium	<input type="text"/>	
<input type="checkbox"/> State of medium	<input type="checkbox"/> liquid	<input type="checkbox"/> gaseous <input type="checkbox"/> vaporous
<input type="checkbox"/> Medium temperature	<input type="text"/> °F	
<input type="checkbox"/> Maximum flow rate	$Q_{nom} =$ <input type="text"/> Unit: <input type="text"/>	
<input type="checkbox"/> Minimum flow rate	$Q_{min} =$ <input type="text"/> Unit: <input type="text"/>	
<input type="checkbox"/> Inlet pressure at nominal operation	$p_1 =$ <input type="text"/> PSIG	
<input type="checkbox"/> Outlet pressure at nominal operation	$p_2 =$ <input type="text"/> PSIG	
<input type="checkbox"/> Maximum inlet pressure	$p_{1max} =$ <input type="text"/> PSIG	
<input type="checkbox"/> Ambient temperature	<input type="text"/> °F	
<b>Additional specifications</b>		
<input type="checkbox"/> Body material	<input type="checkbox"/> Brass	<input type="checkbox"/> Stainless steel
<input type="checkbox"/> Seal material	<input type="checkbox"/> FKM	<input type="checkbox"/> other <input type="text"/>

**Note** Please state all pressure values as **overpressures with** respect to atmospheric [PSIG].

DTS 1000084475 EN Version: B Status: RL (released | freigegeben | validé) printed: 10.07.2008