



2/2-way Proportional Valve

- For high flow rates
- Direct-acting, normally closed
- 0 to 362 PSI¹⁾
- DN 3.0 to 12 mm
- 1/2" and 3/4"

Type 2836 can be combined with...



Type 8605

Control electronics
Cable plug version

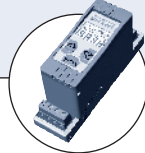

Type 8605

Digital control electronics
DIN-rail version

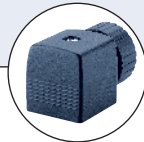

Type 2508

Cable plug

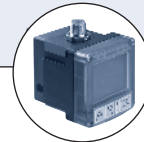

Type 8611

Universal controller

The direct-acting proportional valve Type 2836 works as an electromagnetically actuated control valve in applications with relatively high flow rates. The valve is normally closed.

Valve operation A

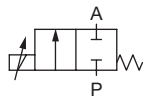

Direct-acting,
2-way proportional valve,
normally closed

Valve control takes place through the control electronics of Type 8605, which converts an analogue input signal into a PWM (pulse-width modulation) signal.

Further, functional features of the Type 8605 electronic control unit:

- Temperature compensation for coil heating by internal current regulation
- Simple zero and span settings
- Ramp function to dampen fast status changes

¹⁾ Pressure data [PSI]: Overpressure with respect to atmospheric pressure

²⁾ PWM pulse-width modulation

³⁾ Characteristic data of control behaviour depends on process conditions

Technical data - valve	
Body material	Brass, stainless steel
Sealing material	FKM, others available on request
Media	neutral gases, liquids, steam on request
Medium temperature	14°F to 194°F (-10°C to +90°C); steam to 284°F (+140°C)
Ambient temperature	max. 131°F (+55°C)
Viscosity	max. 21 cSt
Operating voltage	24 V DC
Power consumption	max. 30 W
Duty cycle	100% continuously rated
Port connection	NPT 1/2, NPT 3/4, G 1/2 and G 3/4, others on request
Electrical connection	Cable plug Type 2508 acc. to DIN EN 175301-803* form A
Mounting position	any, preferably with drive at top
Typical control data³⁾	
Hysteresis	< 5 %
Repeatability	< 1 % of F.S.
Sensitivity	< 0.5 % of F.S.
Turn-down ratio	1:25
Protection class - valve	IP65

Technical data - Control electronics unit Type 8605 (see separate datasheet)

Dimensions [mm]

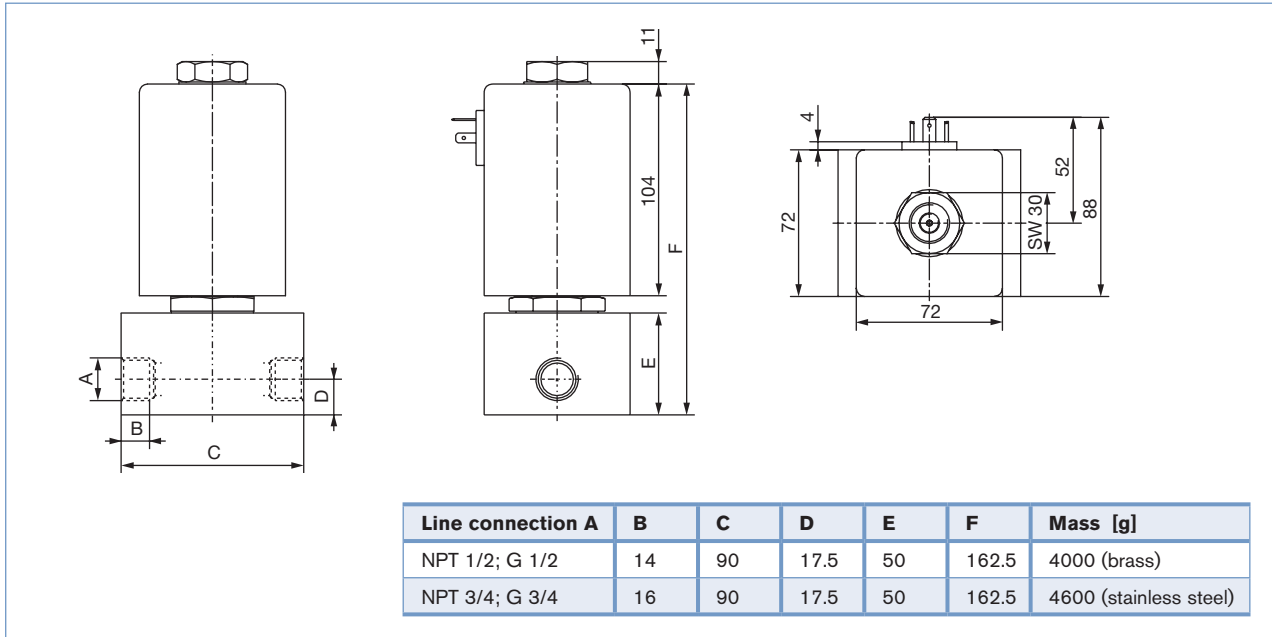

Characteristics of a proportional valve

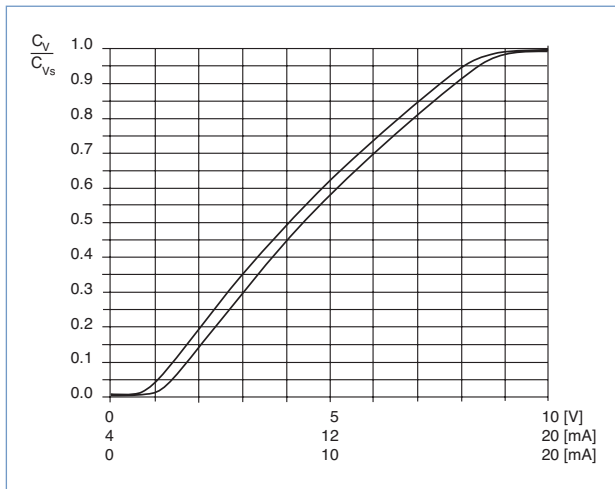

Advice for valve sizing

In continuous flow applications, the choice of appropriate valve size is much more important than with on/off valves. The optimum size should be selected such that the resulting flow in the system is not unnecessarily reduced by the valve. However, a sufficient part of the pressure drop should be taken across the valve even when it is fully opened.

Recommended value: $\Delta p_{\text{valve}} > 30\%$ of total pressure drop within the system

For that reason take advantage of Bürkert competent engineering services during the planning phase!

Determination of the Cv value

Pressure drops	Cv value for liquids [GPM]	Cv value for air and gasses [SCFM]
Subcritical ($p_2 > p_1 \times .53$)	$C_v = \frac{Q_L \sqrt{Sg}}{\sqrt{\Delta p}}$	$C_v = \frac{Q_g \sqrt{Sg}}{\sqrt{\Delta p \times p_2}}$
Supercritical ($p_2 < p_1 \times .53$)	$C_v = \frac{Q_L \sqrt{Sg}}{\sqrt{\Delta p}}$	$C_v = \frac{Q_g \times 2 \sqrt{Sg}}{p_1}$

- C_v = Liquids – flow coefficient in GPM at 1 PSI Δp
Gasses – flow coefficient in SCFM for each PSIG of inlet pressure
- Sg = Specific gravity (Specific gravity of air and water @ 60°F=1)
- p_1 = Inlet pressure in PSIA
- p_2 = Outlet pressure in PSIA
- Δp = Differential pressure ($p_1 - p_2$)
- PSIA = Gauge pressure (PSIG) + 14.7
- Q_L = Liquid flow in GPM
- Q_g = Gas flow in SCFM

Characteristic Values with Ordering chart (other versions on request)

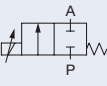
Valve operation	Orifice [mm]	Port connection	C _{v5} value water [GPM] ¹⁾	Q _{Nn} value [l/min] ²⁾	Maximum operating pressure [PSI] ³⁾	Item no. brass body	Item no. stainless steel body
	3	G 1/2	0.29	270	362.5	154 541	154 542
		NPT 1/2	0.29	270	362.5	164 592	-
	4	G 1/2	0.46	430	232	154 543	154 544
		NPT 1/2	0.46	430	232	164 593	-
		G 3/4	1.05	970	116	154 546	154 547
	6	NPT 1/2	1.05	970	116	164 594	-
		G 3/4	1.05	970	116	154 546	154 547
		NPT 3/4	1.05	970	116	164 595	-
	8	G 1/2	1.7	1615	72.5	154 548	154 549
		NPT 1/2	1.7	1615	72.5	164 596	-
		G 3/4	1.7	1615	72.5	154 550	154 551
		NPT 3/4	1.7	1615	72.5	164 597	-
10	G 3/4	2.3	2150	43.5	154 552	154 553	
	NPT 3/4	2.3	2150	43.5	164 598	-	
12	G 3/4	2.9	2700	29	154 554	154 555	
	NPT 3/4	2.9	2700	29	164 599	-	

1) C_{v5} value: Flow rate value for water, measured at 68°F (+20°C) and 1 PSI pressure differential over a fully opened valve.

2) Q_{Nn} value: Flow rate value for air with inlet pressure of 87 PSI¹⁾, 14.5 PSI pressure differential and 68°F (+20°C).

3) Pressure data [PSI]: Overpressure with respect to atmospheric pressure

Please note that the valves are delivered without control electronics unit and cable plug (see accessories below).

Ordering chart for accessories

Cable plug Type 2508 according to DIN EN 175301-803 Form A

The delivery of a cable plug includes the flat seal and fixing screw

Circuitry	Voltage / frequency	Item no.
None	0 - 250 V AC/DC	008 376
None, with 3 m cable	0 - 250 V AC/DC	783 573

Electronic Control Type 8605

Please see datasheet

For product inquiries, use the specification sheet for proportional valves!

Note
You can fill out the fields directly in the PDF file before printing out the form.

Design data for proportional valves

▶ Please fill out this form and send to your local Bürkert Sales Centre* with your inquiry or order

Company	Contact person
Customer no.	Dept.
Address	Tel./Fax
Town / Postcode	E-Mail

<input type="checkbox"/> = Mandatory fields	<input type="text"/> Quantity	<input type="text"/> Desired delivery date
Process data		
<input type="checkbox"/> Medium	<input type="text"/>	
<input type="checkbox"/> State of medium	<input type="checkbox"/> liquid	<input type="checkbox"/> gaseous <input type="checkbox"/> vaporous
<input type="checkbox"/> Medium temperature	<input type="text"/> °F	
<input type="checkbox"/> Maximum flow rate	$Q_{nom} =$ <input type="text"/>	Unit: <input type="text"/>
<input type="checkbox"/> Minimum flow rate	$Q_{min} =$ <input type="text"/>	Unit: <input type="text"/>
<input type="checkbox"/> Inlet pressure at nominal operation	$p_1 =$ <input type="text"/>	PSIG
<input type="checkbox"/> Outlet pressure at nominal operation	$p_2 =$ <input type="text"/>	PSIG
<input type="checkbox"/> Maximum inlet pressure	$p_{1max} =$ <input type="text"/>	PSIG
<input type="checkbox"/> Ambient temperature	<input type="text"/> °F	
Additional specifications		
<input type="checkbox"/> Body material	<input type="checkbox"/> Brass	<input type="checkbox"/> Stainless steel
<input type="checkbox"/> Seal material	<input type="checkbox"/> FKM	<input type="checkbox"/> other <input type="text"/>

Note Please state all pressure values as **overpressures with** respect to atmospheric [PSIG].

DTS 1000084478 EN Version: B Status: RL (released | freigegeben | validé) printed: 10.07.2008